

External grooving and parting off tools

Außeneinstechen und Abstechen

Ranurado exterior y Tronzado

外径溝入れおよび突っ切り加工

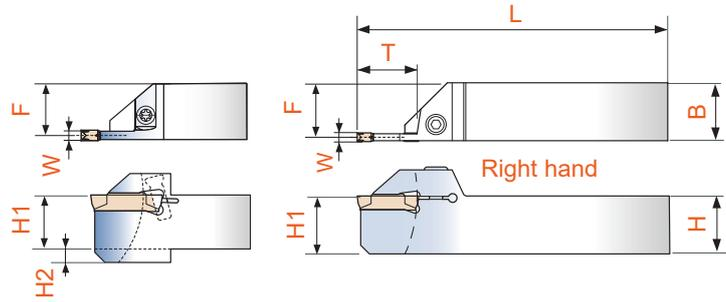
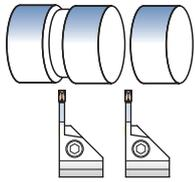

MGEHR / L	Example / Order code : MGEHR-1010K-2TH10T									
Grooving tools	H(H1)	B	T	L	F	H2	Inserts			
MGEHR / L -1010K-2.0TH10T	10	10	10	125	9.25	2	MGMN 200	MS4013F	-	ETL15
MGEHR / L -1212K-2.0TH12T	12	12	12	125	11.25	2	MGMN 200	MS4013F	-	ETL15
MGEHR / L -1212K-2.5TH13T		13	11.00	2	MGMN 250					
MGEHR / L -1616K-2.0TH12T	16		12		15.25		MGMN 200	MS4013F	-	ETL15
MGEHR / L -1616K-2.0TH16T		16	16	125	15.25	-	MGMN 200	-	HTMT520	ETL25
MGEHR / L -1616K-3.0TH20T		20			14.80		MGMN 250	-	HTMT520	ETL25
MGEHR / L -2020K-2.0TH20T	20		20		19.25		MGMN 200	-	HTMT525	ETL25
MGEHR / L -2020K-3.0TH20T		20	20	125	18.80	-	MGMN 300			
MGEHR / L -2020K-4.0TH20T		20			18.35		MGMN 400			
MGEHR / L -2525M-2.0TH20T	25		20		24.25		MGMN 200	-	HTMT525	ETL25
MGEHR / L -2525M-3.0TH20T		25	20	150	23.80	-	MGMN 300			
MGEHR / L -2525M-4.0TH20T		20			23.35		MGMN 400			
MGEHR / L -2525M-5.0TH25T		25			22.85		MGMN 500			

Inserts
Wendeschneidplatten
Plaquetas
チップ

MGMN



Grooving

Size	L	W	Size	L	W
200	16.0	2.0	400	21.0	4.0
250	18.5	2.5	500	26.0	5.0
300	21.0	3.0			

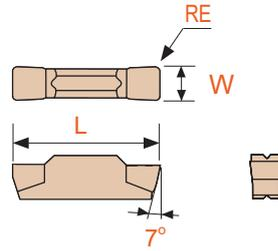

Grooving Inserts		Grade	Coating	P	M	K	N	S	H	RE	fz (mm/rev)	
Grooving	MGMN 200-G	KT2415	PVD	☺	☹					0.2	0.02 - 0.10	
	MGMN 250-M	KT2415	PVD	☺	☹					0.2	0.02 - 0.12	
	MGMN 300-M	KT2415	PVD	☺	☹					0.4	0.03 - 0.15	
	MGMN 400-M	KT2415	PVD	☺	☹					0.4	0.08 - 0.25	
	MGMN 500-M	KT2415	PVD	☺	☹					0.8	0.10 - 0.35	