

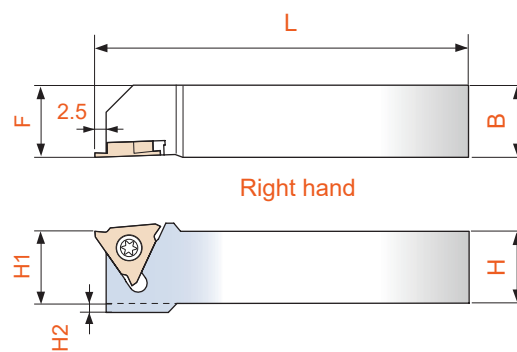

External grooving tools

Außeneinstechen
Ranurado exterior
外径溝入れ加工

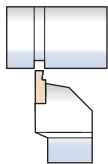

KTGFR / L	Example / Order code : KTGFR-1010K-16F						
Grooving tools	H(H1)	B	L	F	H2	Inserts	 
KTGFR / L -1010K-16F KTGFR / L -1012K-16F	10	10	125	10 12	4 2	TGF32R ..	MS4009A MS4011A ETF15
KTGFR / L -1212K-16F	12	12	125	12	2	TGF32R ..	MS4011A ETF15
KTGFR / L -1616K-16F KTGFR / L -1616K-16B	16	16	125	16 20	-	TGF32R ..	MS4011A ETF15
KTGFR / L -2020K-16F KTGFR / L -2020K-16B	20	20	125	20 25	-	TGF32R ..	MS4011A ETF15
KTGFR / L -2525M-16B	25	25	150	32	-	TGF32R ..	MS4011A ETF15

Inserts
Wendeschneidplatten
Plaquetas
チップ

Mark: Left hand inserts
Example / Order code : TGF 32L050-005

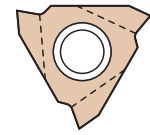
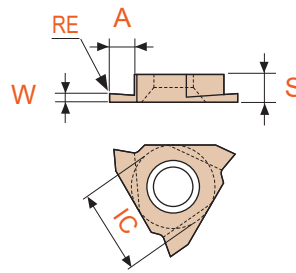

Grooving

Size	IC	S
32	9.525	3.18

Grooving Inserts		Grade	Coating	P	M	K	N	S	H	W	A	RE	
Grooving	TGF 32R050-005	KT3020	PVD	●	●					0.50	1.2	0.05	
		KT0110	-			●	●			0.50	1.2	0.05	
	32R050-025	KT3020	PVD	●	●					0.50	1.2	0.25	
		KT0110	-			●	●			0.50	1.2	0.25	
	32R075-010	KT3020	PVD	●	●					0.75	2.0	0.10	
		KT0110	-			●	●			0.75	2.0	0.10	
	32R095-010	KT3020	PVD	●	●					0.95	2.0	0.10	
		KT0110	-			●	●			0.95	2.0	0.10	
	32R100-010	KT3020	PVD	●	●					1.00	2.0	0.10	
		KT0110	-			●	●			1.00	2.0	0.10	
	32R100-050	KT3020	PVD	●	●					1.00	2.0	0.50	
		KT0110	-			●	●			1.00	2.0	0.50	
	32R150-010	KT3020	PVD	●	●					1.50	2.0	0.10	
		KT0110	-			●	●			1.50	2.0	0.10	
	32R150-075	KT3020	PVD	●	●					1.50	2.0	0.75	
KT0110		-			●	●			1.50	2.0	0.75		
32R175-010	KT3020	PVD	●	●					1.75	2.0	0.10		
	KT0110	-			●	●			1.75	2.0	0.10		
32R200-010	KT3020	PVD	●	●					2.00	2.5	0.10		
	KT0110	-			●	●			2.00	2.5	0.10		
32R200-100	KT3020	PVD	●	●					2.00	2.5	1.00		
	KT0110	-			●	●			2.00	2.5	1.00		
32R250-010	KT3020	PVD	●	●					2.50	2.5	0.10		
	KT0110	-			●	●			2.50	2.5	0.10		
32R250-125	KT3020	PVD	●	●					2.50	2.5	1.25		
	KT0110	-			●	●			2.50	2.5	1.25		