

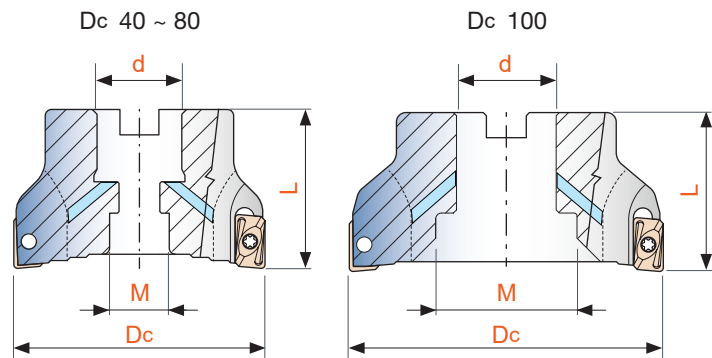



Shoulder milling cutters



Eckfräser

Fresado en escuadra

肩削りフライス加工



BAP3		Example / Order code : BAP3-0405-A16							 	
Cutters		Dc	d	L	M	Z		Inserts		
BAP3-0405-A16	40	16	40	9	5	Y		APMT 1135	MS2506E	ETF08
BAP3-0406-A16	40				6	Y				
BAP3-0505-A22	50	22	40	11	5	Y		APMT 1135	MS2506E	ETF08
BAP3-0507-A22	50				7	Y				
BAP3-0638-A22	63	22	40	11	8	Y		APMT 1135	MS2506E	ETF08

BAP4		Example / Order code : BAP4-0404-A16							 	
Cutters		Dc	d	L	M	Z		Inserts		
BAP4-0404-A16	40	16	40	9	4	Y		APMT 1604	MS4011A	ETF15
BAP4-0505-A22	50	22	50	11	5	Y		APMT 1604	MS4011A	ETF15
BAP4-0636-A22	63	22	50	11	6	Y		APMT 1604	MS4011A	ETF15
BAP4-0808-A27	80	27	50	13	8	Y		APMT 1604	MS4011A	ETF15
BAP4-1008-A32	100	32	50	45	8	Y		APMT 1604	MS4011A	ETF15

--	--	--	--	--	--	--	--	--	--	--

Inserts
Wendeschneidplatten
Plaquitas
チップ

APMT / APGT

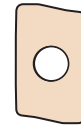

2 Cutting edges

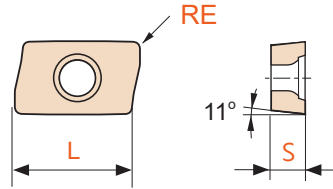

Size	L	S
1135	11.0	3.50
1604	16.0	4.76

Milling Inserts		Grade	Coating	P	M	K	N	S	H	RE	fz (mm/t)	Ap (mm)	
APMT	1135 PDER-H2	KM1520	PVD	●	○	●				0.8	0.12 - 0.26	0.30 - 4.0	
		KM1530	PVD	●	●	●				0.8	0.10 - 0.24	0.30 - 4.0	
	1135 PDER-M2	KM1520	PVD	●	○	●				0.8	0.12 - 0.26	0.30 - 4.0	
		KM1530	PVD	●	●	●				0.8	0.10 - 0.24	0.30 - 4.0	
APMT	1604 PDER-H2	KM1520	PVD	●	○	●				0.8	0.14 - 0.32	0.50 - 6.0	
		KM1530	PVD	●	●	●				0.8	0.12 - 0.30	0.50 - 6.0	
	1604 PDER-M2	KM1520	PVD	●	○	●				0.8	0.14 - 0.32	0.50 - 6.0	
		KM1530	PVD	●	●	●				0.8	0.12 - 0.30	0.50 - 6.0	
APGT	1135 PDER-G2	KM10F	-				●			0.8	0.10 - 0.30	0.30 - 4.0	
	1604 PDER-G2	KM10F	-				●			0.8	0.12 - 0.40	0.50 - 6.0	