

Inserts  
Wendeschneidplatten  
Plaquetas  
チップ

BLMP

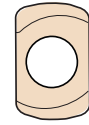

4 Cutting edges

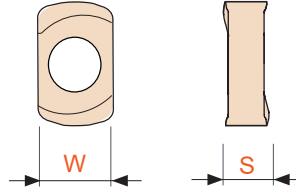

| Size | W    | S    |
|------|------|------|
| 0603 | 6.39 | 3.73 |

| Milling Inserts      | Grade            | Coating    | P | M | K | N | S | H | fz (mm/t)                  | Ap (mm)                  |
|----------------------|------------------|------------|---|---|---|---|---|---|----------------------------|--------------------------|
| <b>BLMP</b> 0603 R-M | KM1520<br>KM1530 | PVD<br>PVD | ☹ | ☺ | ☹ | ☺ | ☺ | ☹ | 0.27 - 2.00<br>0.25 - 1.80 | 0.10 - 0.8<br>0.10 - 0.8 |



Tool geometry on programming  
Werkzeugbahnprogrammierung  
Geometría de la herramienta en la programación  
プログラム上の刃先形状

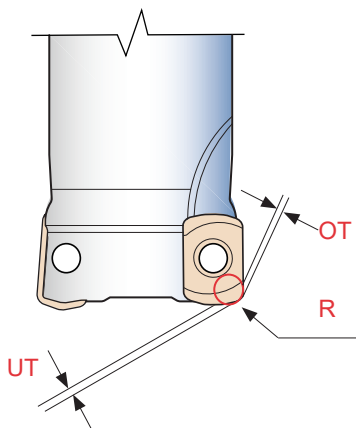

| R (mm)<br>program | UT (mm)<br>uncut | OT (mm)<br>overcut |
|-------------------|------------------|--------------------|
| 2.0               | 0.42             | -                  |
| 2.5               | 0.26             | 0.12               |
| 3.0               | 0.17             | 0.29               |