

### Face milling tools 45°

Planfräser

Planeado

正面フライス加工

Dc 50 ~ 80

Dc 100 ~ 160

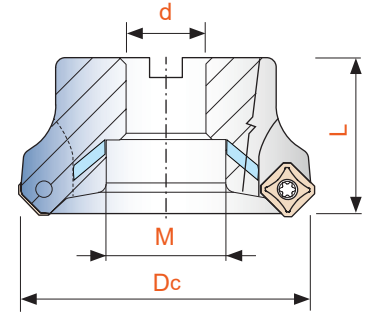
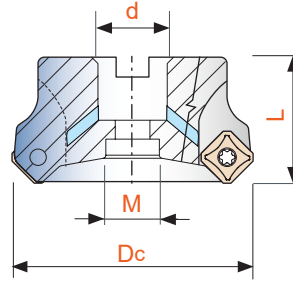

SNF445R Right-hand Cutters	Example / Order code : <b>SNF445R-05004-A22</b>											
	Dc	d	L	M	Z		Inserts					
SNF445R-05004-A22 SNF445R-05005-A22	50 50	22	40	11	4 5	Y Y	SNMX 1205	SNS445A	MDS06040	PL40	MDS06040	ETF15
SNF445R-06305-A22 SNF445R-06306-A22	63 63	22	40	11	5 6	Y Y	SNMX 1205	SNS445A	MDS06040	PL40	MDS06040	ETF15
SNF445R-08006-A27 SNF445R-08007-A27 SNF445R-08008-A27	80 80 80	27	50	13	6 7 8	Y Y Y	SNMX 1205	SNS445A	MDS06040	PL40	MDS06040	ETF15
SNF445R-10007-A32 SNF445R-10008-A32 SNF445R-10009-A32	100 100 100	32	50	45	7 8 9	Y Y Y	SNMX 1205	SNS445A	MDS06040	PL40	MDS06040	ETF15
SNF445R-12510-A40	125	40	63	55	10	Y	SNMX 1205	SNS445A	MDS06040	PL40	MDS06040	ETF15
SNF445R-16012-A40	160	40	63	55	12	Y	SNMX 1205	SNS445A	MDS06040	PL40	MDS06040	ETF15

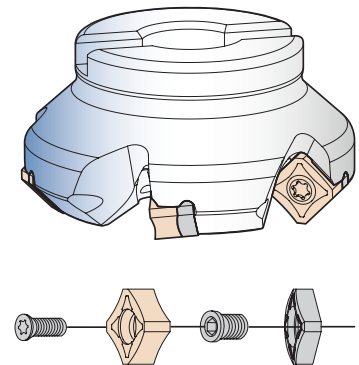

Inserts  
Wendeschneidplatten  
Plaquetas  
チップ

SNMX

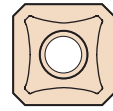

8 Cutting edges

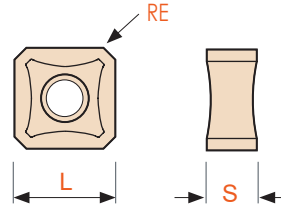

Size	L	S
1205	12.0	6.35

Milling Inserts	Grade	Coating	P	M	K	N	S	H	RE	fz (mm/t)	Ap (mm)
<b>SNMX</b> 1205 ANN-M	KM1520	PVD	☐	☐	☐	☐	☐	☐	0.8	0.08 - 0.38	0.50 - 5.0
	KM1530	PVD	☐	☐	☐	☐	☐	☐	0.8	0.06 - 0.35	0.50 - 5.0

--	--	--	--	--	--	--	--	--	--	--	--