

### Face milling tools 45°

Planfräser

Planeado

正面フライス加工

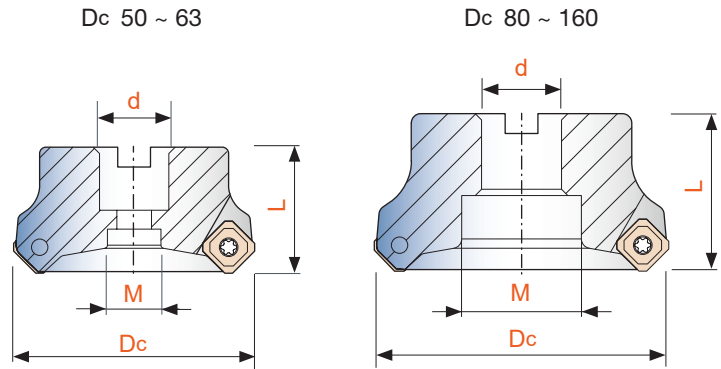

ASX445		Example / Order code : <b>ASX445R-050A03R-22</b>												
Right-hand Cutters		Dc	d	L	M	Z	Inserts							
<b>ASX445-050A03R-22</b>	50					3	N							
<b>ASX445-050A04R-22</b>	50	22	40	11		4	N	SEMT 13T3	SSS445N	MDS05035	PL35	MS3512B	ETF15	
<b>ASX445-050A05R-22</b>	50					5	N							
<b>ASX445-063A04R-22</b>	63					4	N							
<b>ASX445-063A05R-22</b>	63	22	40	11		5	N	SEMT 13T3	SSS445N	MDS05035	PL35	MS3512B	ETF15	
<b>ASX445-063A06R-22</b>	63					6	N							
<b>ASX445-080A04R-27</b>	80					4	N							
<b>ASX445-080A06R-27</b>	80	27	50	38		6	N	SEMT 13T3	SSS445N	MDS05035	PL35	MS3512B	ETF15	
<b>ASX445-080A08R-27</b>	80					8	N							
<b>ASX445-100B05R-32</b>	100					5	N							
<b>ASX445-100B07R-32</b>	100	32	50	45		7	N	SEMT 13T3	SSS445N	MDS05035	PL35	MS3512B	ETF15	
<b>ASX445-100B10R-32</b>	100					10	N							
<b>ASX445-125B06R-40</b>	125					6	N							
<b>ASX445-125B08R-40</b>	125	40	63	60		8	N	SEMT 13T3	SSS445N	MDS05035	PL35	MS3512B	ETF15	
<b>ASX445-125B12R-40</b>	125					12	N							
<b>ASX445-160B07R-40</b>	160					7	N							
<b>ASX445-160B10R-40</b>	160	40	63	80		10	N	SEMT 13T3	SSS445N	MDS05035	PL35	MS3512B	ETF15	
<b>ASX445-160B16R-40</b>	160					16	N							

Inserts  
Wendeschneidplatten  
Plaquetas  
チップ

SEMT

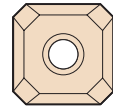

4 Cutting edges

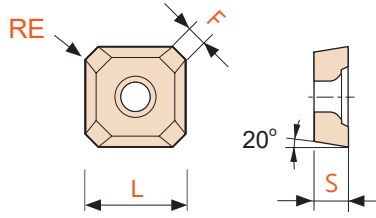

Size	L	F	S
13T3	13.4	1.4	3.97

Milling Inserts		Grade	Coating	P	M	K	N	S	H	RE	fz (mm/t)	Ap (mm)
<b>SEMT</b>	13T3 AGTN-M	KM1520	PVD	☑	☑	☑	☑	☑	☑	1.5	0.12 - 0.38	0.50 - 5.0
		KM1530	PVD	☑	☑	☑	☑	☑	☑	1.5	0.10 - 0.36	0.50 - 5.0

--	--	--	--	--	--	--	--	--	--	--	--	--